

Optical Control Systems GmbH
Wullener Feld 36
58454 Witten, Germany
Tel: +49 (0) 2302 956 22-0
Fax: +49 (0) 2302 956 22-33
e-mail: info@ocsgmbh.com
<http://www.ocsgmbh.com>

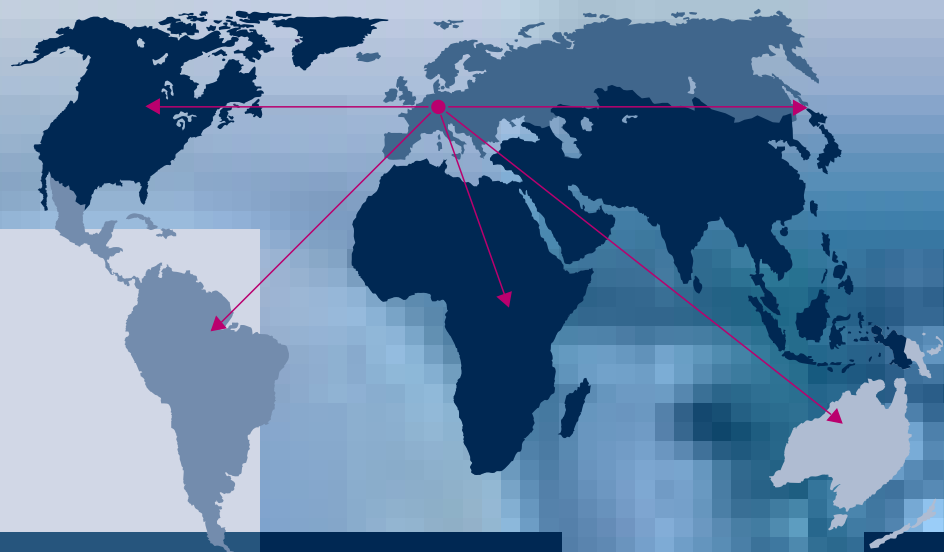

The Solution for the Polymer Industry



**Chill Roll and Winding
Systems Types
CR7 / CR8**

The Original by OCS

Chill Roll and Winding Systems Types CR 7 / CR 8

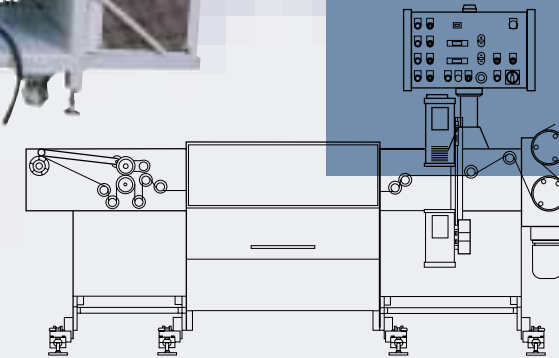
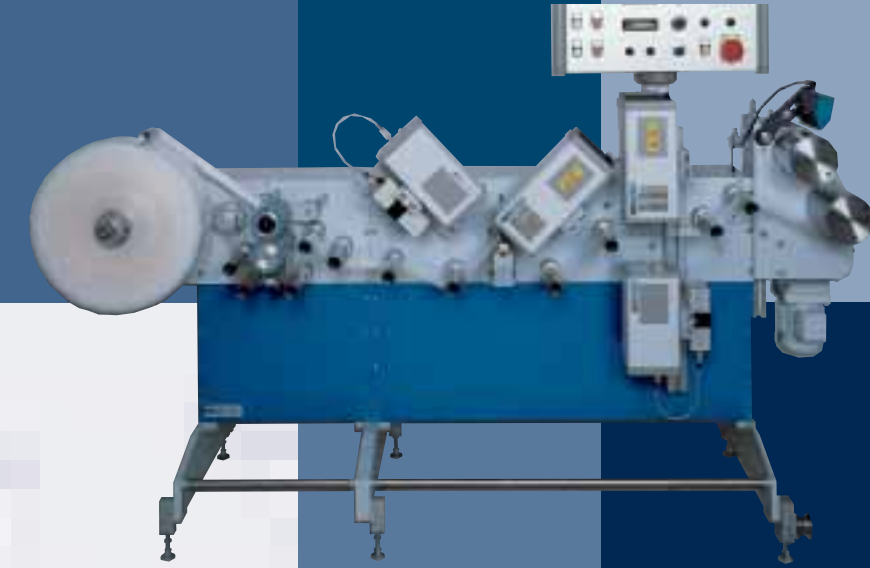

CR 7 / CR 8

The two chill roll and winding systems type CR 7 / CR 8 (the CR 8 can contain an FTIR box for Online Infrared Spectroscopy, Haze-, Gloss- and Thickness-Measurement) have been specially developed to meet the requirements of the plastics-producing and processing industries. They serve to produce a defined cast or blown film for continuous purity inspection in conjunction, for example, with a film quality measuring system FS5 or FSA100. The unit CR 8 can also be expanded to include an FTIR spectrometer which offers the possibility of determining additive contents in the polymer online, establishing their concentrations and measuring other physical properties of the polymer. Both extruder downstream units can be individually adapted to suit a large number of polymers and therefore help to optimise extrusion conditions. Temperature-controlled chill rolls positioned one above the other pull the extruded film from a cast film die. Freely programmable parameters such as chill roll speed, temperature of the chill rolls and tensile force of the winder permit a defined and reproducible setting of a cast film of the desired thickness. Supplementary safety features, such as, for example, visual and acoustic alarms in the event of a film break or when the winder is full, permit independent operations. Easy reel-changing and lateral and /or axial mobility of the entire chill roll unit permit convenient handling. All the functions of the CR 7 and CR 8 can be monitored and set on a well-arranged control panel.

Performance features

- **Modular design**
Simple possibility of expansion, easy adaptation
- **Use of selected material**
All important contact surfaces are made of stainless steel
- **Robust drive technology**
The high-performance drives are monitored electronically and mechanically
- **Self-diagnosis**
Constant display and monitoring of chill roll speed, tensile force setting and winder status
- **Mobility**
Tracks movable in longitudinal and transverse directions make for convenient handling
- **Operation**
Ergonomic, swivel-type control panel
- **Alarm functions**
Optical and acoustic alarms
- **Interfaces for external equipment**
ACS remote control, Profibus, RS485
- **Process synchronisation**
Winder linked by hysteresis coupling to rubber nip rolls. Control can be linked to external measuring equipment, e.g. FSA 100, TM 9, Gamma 12
- **Integration of FTIR spectrometer**
Optionally, an FTIR spectrometer can be integrated into the system

- **Integration of TM 9 Thickness Measuring Unit**
A thickness measuring device can be optionally integrated into the system.
- **Integration of Gamma 12 Haze Measuring Unit**
An online hazemeter can be optionally integrated into the system.

Accessories

- Film Test FS 5 or FSA 100
- Online Hazemeter Gamma12
- Thickness meas. unit TM 9
- Label printer
- FTIR spectrometer
- Gloss measurement
- Pimple meas. PM 5

Fields of application

- **Quality control in laboratory**
- **Small-batch production**
The host of applications can be extended by the use of numerous accessories:
- **Winding up of cast film**
- **Measurement of the film quality**
- **Quality control of the raw material production**
- **Quality control of incoming goods**

Technical data

- **Drive technology**
Asynchronous drive unit with vector controller
Rating 0.25 kW
Max. production speed 10 m/min
- **Chill rolls**
Diameter 140 mm
Width 200 mm or 300 mm
Working width 180 mm or 280 mm
Material stainless steel chrome-plated or with anti-stick coating
Temp. ranges 5 ... 85 °C Standard
optional 5 ... 140 °C
elec. heatable over 140 °C
- **Guide rolls**
Diameter 40 mm
Working width 180 mm or 280 mm
Material stainless steel
- **Rubber nip rolls**
Diameter 90 mm
Working width 180 mm or 280 mm
Tensile force max. 10 N
Material stainless steel rubber-coated
- **Winder**
Winder tube 100 mm
Max. winding Ø 600 mm
Drive Hysteresis coupling at winder device

OCS - Optical Control Systems GmbH

Our continued goal

Our continued goal is to provide the polymer industry with quality control systems that are optimised with regard to production and purpose, and to offer complete solutions with solid and up-to-date technology at reasonable prices. To achieve this we constantly improve our production expertise and technical knowledge, and widen our all-round understanding of functional requirements.

OCS is committed to provide quality products and service to its customers within the agreed delivery time. OCS will strive to continuously improve quality, delivery and responsiveness to assure customer satisfaction.

OCS strives to widen our world-wide market share to be the world-leader in providing the highest value products and services to our customers.

- **Interfaces**
Modbus, Profibus, FSA 100 link
- **ACS remote control**
Industrial computer Pentium IV technology
Software ACS with Win. operating system
- **Main Power**
Power supply 230 V, 50/60 Hz, 1 kW
- **Weight**
Total weight without accessories approx. 350 kg
- **Dimensions**
CR 7 1400 x 750 x 1560 mm
(L x W x H)
CR 8 2430 x 790 x 1560 mm
(L x W x H)
Working height 1100 mm